

Applications

REFINERY DE-SCALING APPLICATIONS:

- Heat Exchangers
- All type crackers
- Converters
- Air & Gas Compressors
- Pumps
- Piping



PAPER MILL DE-SCALING APPLICATIONS:

- Liquid-Ring Vacuum Pumps & Filters
- Calendar Rolls
- Mill Rolls
- Liquor Tanks
- Pulverizers



How do you determine the amount of Sublime® needed for a cleaning?

- Consult with maintenance supervisor to determine equipment specifications
- Consult OEM drawings
- Estimate pipe capacity
- Estimate approximately 30% of body or cylinder size
- Make sure you have spare quantities available

PIPE CAPACITY

PIPE DIAMETER	FEET/GAL
1/8"	338
1/4"	185
3/8"	100
1/2"	63
3/4"	36
1 "	22
1 1/4"	12.8
1 1/2"	9.45
2"	5.73
2 1/2"	4.02

PIPE DIAMETER	FEET/GAL
3"	2.60
3 1/2"	1.95
4 "	1.57
5"	.96
6"	.66
7"	.49
8"	.40
10"	.24
12"	.17
14"	.12

GALLONS REQUIRED = TOTAL LENGTH OF PIPE / FEET PER GALLON

(Figure 3.)

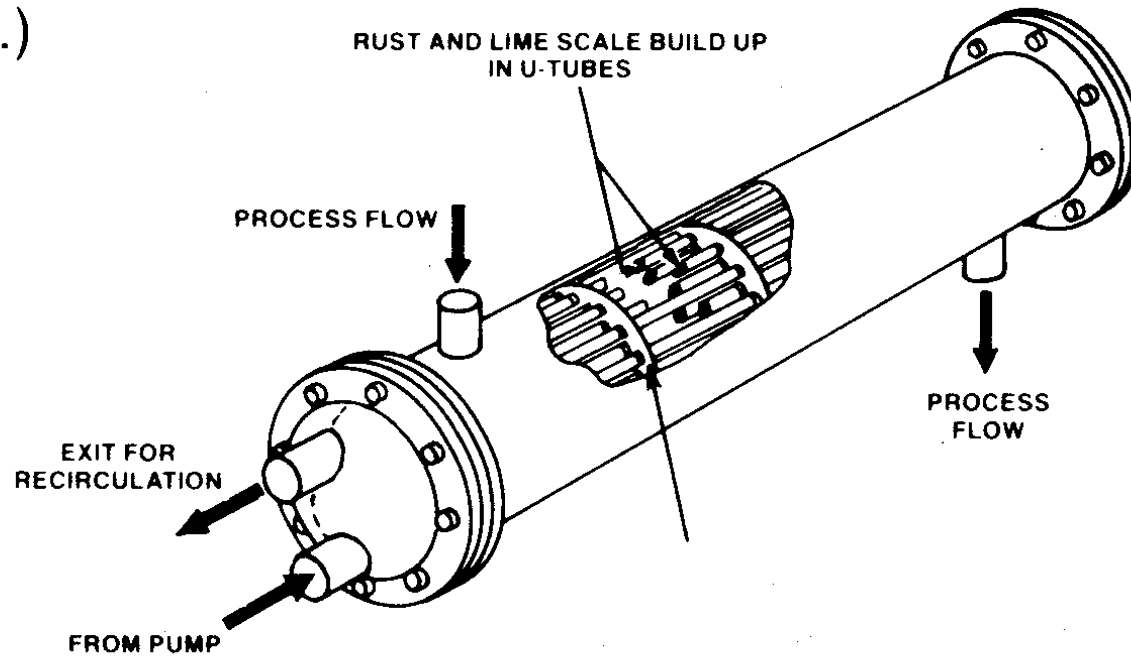

HEAT EXCHANGER CAPACITIES

	LENGTH IN FEET									
DIA.	1	2	5	10	12	15	20	25	30	40
6"	1	2	4	8	9	11	15	19	22	30
12"	3	6	15	30	35	44	59	74	88	118
18"	7	13	33	66	80	99	133	166	199	265
24"	12	24	59	118	141	177	236	295	353	471
30"	19	37	92	184	221	276	368	460	552	736
36"	27	53	133	265	318	398	530	663	795	1060
42"	36	72	180	361	433	541	722	902	1082	1443
48"	47	94	236	471	566	707	943	1178	1414	1885
54"	60	119	298	596	716	895	1193	1491	1789	2386
60"	74	147	368	736	884	1105	1473	1841	2209	2945
66"	89	178	445	891	1069	1336	1782	2227	2673	3564
72"	106	212	530	1060	1272	1590	2121	2651	3181	4241
78"	125	249	622	1244	1493	1867	2489	3111	3733	4978

NUMBERS REPRESENT A 50% SOLUTION



Descalers and Degreasers
Klüber Lubrication NA LP

PRESENTER: RODNEY RUSHING
DATE: MARCH 9, 2016

a brand of  **FREUDENBERG**

(Figure 1.)

